

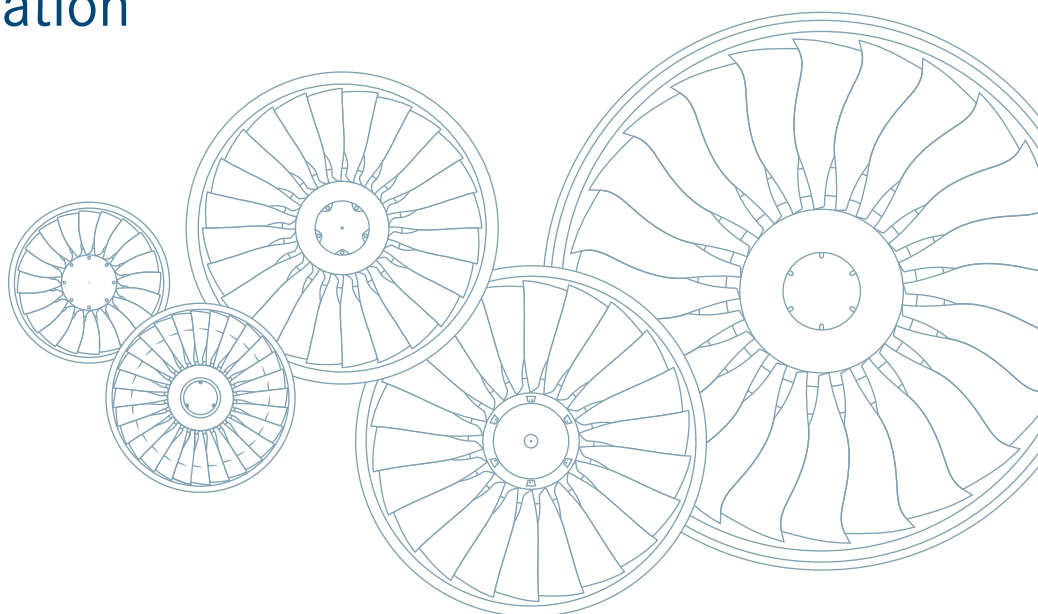

Measurement techniques and instrumentation



Our competencies and services

MTU Aero Engines is Germany's leading engine manufacturer.

MTU designs, develops, manufactures, assembles, markets and supports commercial and military engines, as well as industrial gas turbines. Through cooperation with the world's largest engine makers, MTU has been involved in major engine programs for decades and has a presence in all major markets.

MTU's validation and measurement department develops advanced sensors and measurement systems. We design, manufacture and install measurement probes and acquire the data to evaluate the particular operating conditions in engine, rig, component and flight tests all over the world.

The highly professional staff with its wide range of experience and the use of advanced design methods, reliable manufacturing and application processes and up to date measuring equipment ensure fast and cost-effective target achievement. Our core capabilities are reflected in the following services:

- Design and integration of instrumentation for turbo machinery
- Manufacturing of standard and customized measurement probes
- Application of measurement sensors and probes to the test vehicles
- Provision of measurement systems including the data acquisition service
- Data analysis and data interpretation



MTU's validation and measurement department offers all services on the way from the design of instrumentation to the analysis of the data for its products.

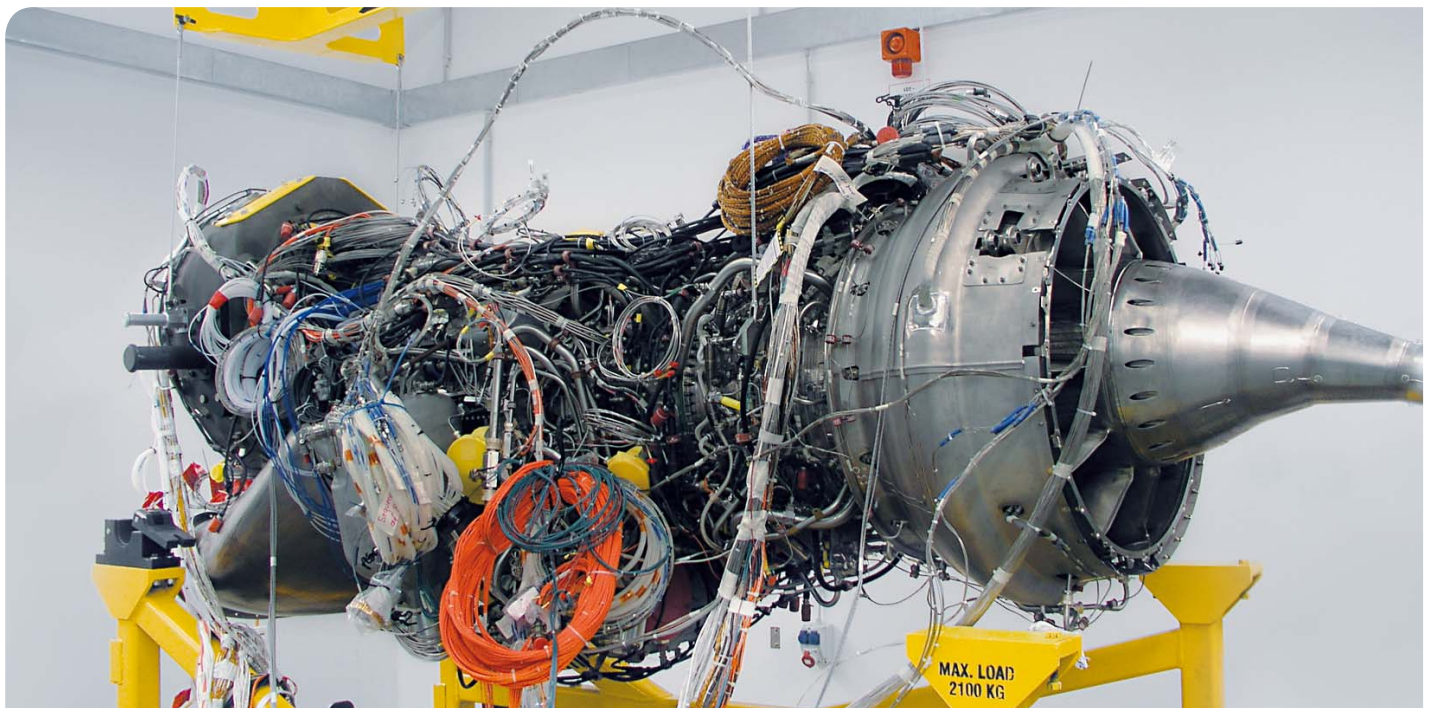

Heavy instrumented test engine.

Development and future technologies

Anticipating future technical requirements and special customer demands the validation and measurement department constantly

- improves existing measurement techniques, instrumentation manufacturing methods and sensors
- develops novel sensors, measurement methods and systems with additional functionality.

This ensures the availability of measurement systems which can support the development and validation of current and future gas turbine engines.

Over 30 years of experience in instrumentation design and manufacturing, measurements, and in-house development of measurement systems lead to a variety of sensors and systems suitable for the harsh environment of gas turbine engine testing.

High accuracy, durability and quality are our key success factors for low- or high-temperature applications on stationary or rotating components with high g-loads.

Development activities:

- Continuous improvement of the MTU digital telemetry system
- BSSM, MTU's tip timing and tip clearance measurement system, has been developed completely in-house.

Ongoing intensive efforts are made to extend the real-time/offline analysis and remote control capabilities for both compressor and shrouded turbine applications

- Further increase of temperature limits and life expectancy for high-temperature strain gauges
- Continuous development of capacitive tip clearance probes
- Development of instrumentation techniques using the latest rapid manufacturing methods, e. g. selective laser melting (SLM)
- Validation of new measurement systems

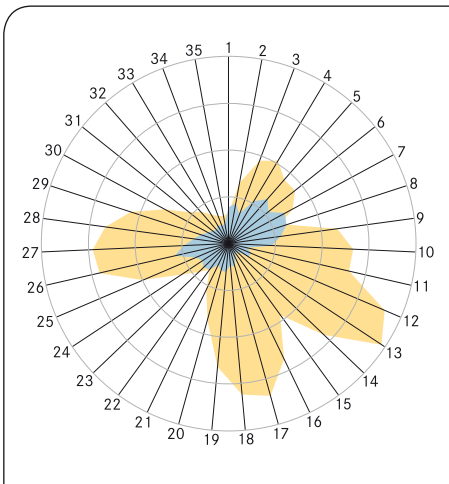

Single blade stress during a surge test.
Mode 1 ■ Mode 2 ■



Optical beam interrupt probe for rig and engine tests.

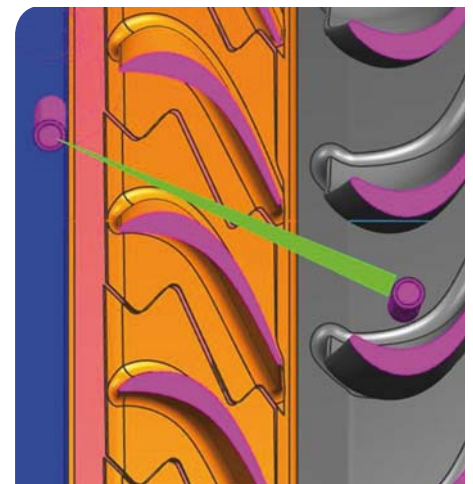

Various types of capacitive probes.



Instrumented vane segment SLM technology.



Instrumented vane segment conventional design.

Products from design to analysis

Assembly and testing of complex rigs and engines involves the coordination and application of standard and specialized instrumentation, measurements and analysis.

Instrumentation Design

- design integration for stationary and rotating components of engines and rigs
- Sensor and rake design
- Development of probe actuation systems
- Design of high-precision mechanical fixtures
- Non-modular instrumentation
- Design integration of telemetry systems

In the process, use is made of digital mock-ups of rigs or engines and the latest CAD systems (Unigraphics).



Instrumentation of a compressor rotor.

Instrumentation manufacturing and application

In manufacturing, milling, drilling and grinding are the standard processes used to machine Ni-base alloys, single-crystal materials, ceramics. Additionally we possess facilities to perform special manufacturing processes such as electro-discharge machining (EDM), vacuum brazing and selective laser melting (SLM). Platinum plating of ceramic parts and brazing processes for joining metals and ceramic materials round out the range of manufacturing techniques.



CAD model of a turbine inlet probe.

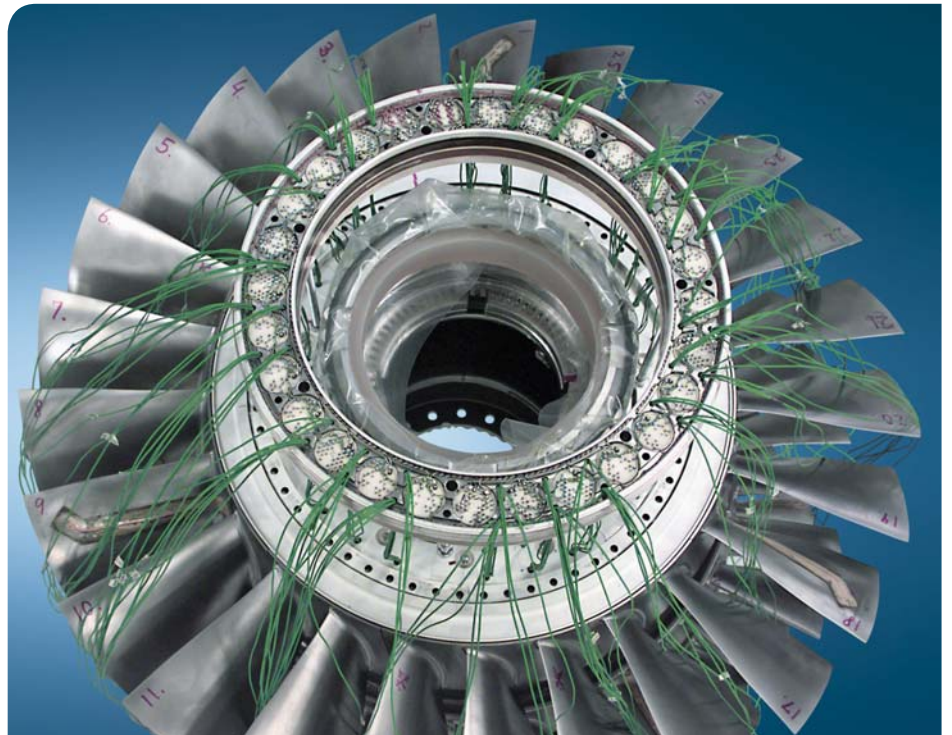

Telemetry system instrumentation.

Products

- Aerodynamical probes for pressure, temperature and flow direction with individual Kiel head orientation (rakes, leading edge)
- Application of thermocouples (TC) and strain gauges (S/G) (hot and cold areas)
- Specialized quick-response thermocouples
- Static profile instrumentation
- Hot-film sensors for vanes
- Uncooled probes for high-temperature measurements
- Capacitive probes for tip clearance and tip timing measurements
- Miniature traversing probes
- Traversing devices
- Optimal beam interrupt probes for blade vibration measurements



Aerodynamical rake.



Leading edge instrumentation.



Turbine rotor blade with strain gauge (max. temp. 1,400 K).

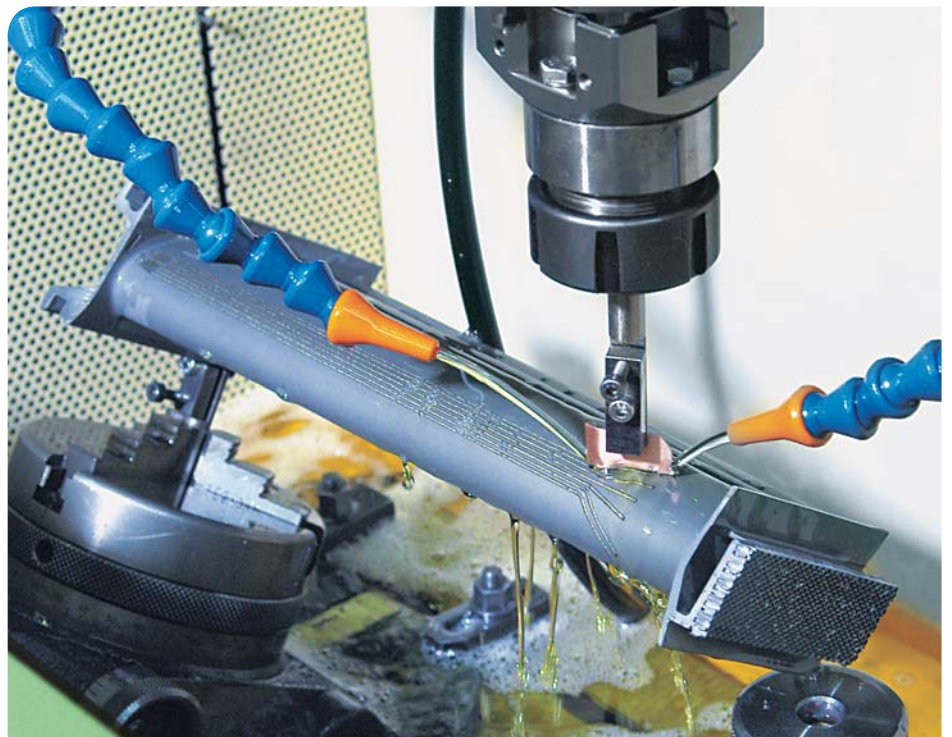

Rework of a turbine vane for instrumentation leads by EDM.

Products from design to analysis

Measurement equipment

The measurement equipment is modular structured for rugged and mobile use on internal and external test facilities or flying test beds. The available number of channels can fulfil existing demands and is easily expandable for future demands. The measurement systems are kept up to date, which ensures most effective test support and quick data availability.

Key systems

- **Dynamic Data System (DDS)**

for acquiring, monitoring and analyzing data from strain gauges, accelerometers, pressure sensors and other probes which require high scanning rates

- Modular configurable number of channels up to 650
- Scanning rate up to 200 kHz
- Online monitoring including alarm panel and online analysis
- Offline analysis and data interpretation
- Cost-effective remote control, monitoring and analysis

- **Tip timing (BSSM)**

- Real-time rotor blade vibrations up to 60th engine order and down to peak amplitudes of 2 μm , using capacitive and optical probes
- Analysis of synchronous vibrations (resonances), asynchronous vibrations (blade flutter und surge loads), blade untwist and crack detection

- **Tip clearance**

Min, max, average tip clearance, rotor orbiting and position and casing deformation can be analysed using the same capacitive probes as for tip timing

- **High speed video system**

recording up to 100.000 frames/s (i.e. ingestion tests)

- **Infrared measurement system**

recording up to 200 frames/s (absolute temperatures, imaging)

- **Telemetry system**

- Fully digital system
- Experience with g-loads up to 60,000
- Induced non-contact power supply
- High bandwidth data transmission
- Simultaneous measurement of stresses and temperatures with separate modules
- Simultaneous 96/48 S/G channels, Bandwidth 25/50 kHz; increase by factor 4 possible with additional selections during engine operation
- 383 static TC channels

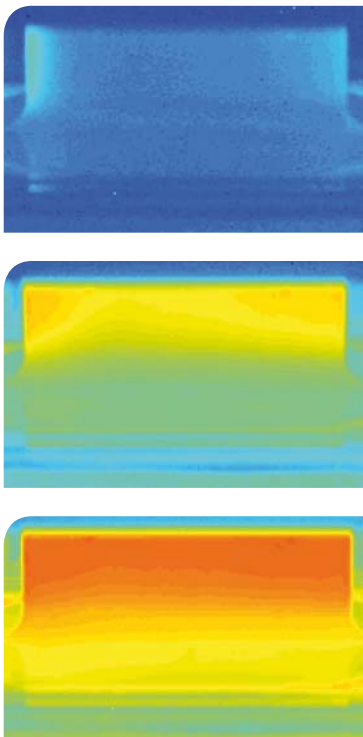

Sequence of IR temperature measurement during shock heating process of a compressor blade.

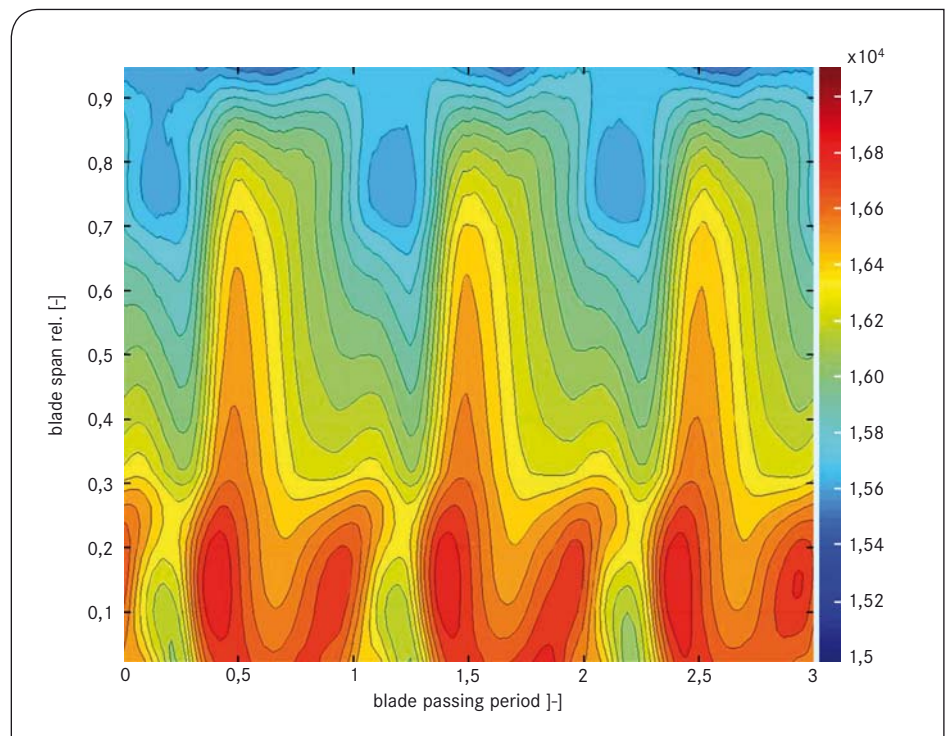

Fast response aerodynamic measurement: Total pressure profile behind 1st rotor of a turbine rig.

Unique turnkey solutions

For most of the products MTU offers turnkey solutions covering all aspects from design, integration, manufacturing, application to analysis of the acquired data. Unique turnkey solutions, based on in-house developments are offered for:

- **Complete digital telemetry systems** including design, integration, manufacturing, instrumentation and data acquisition and analysis
- **Tip timing and tip clearance** measurements including MTU-designed and MTU-manufactured capacitive and optical probes, integration, unique tip timing and tip clearance measurement and analysis systems

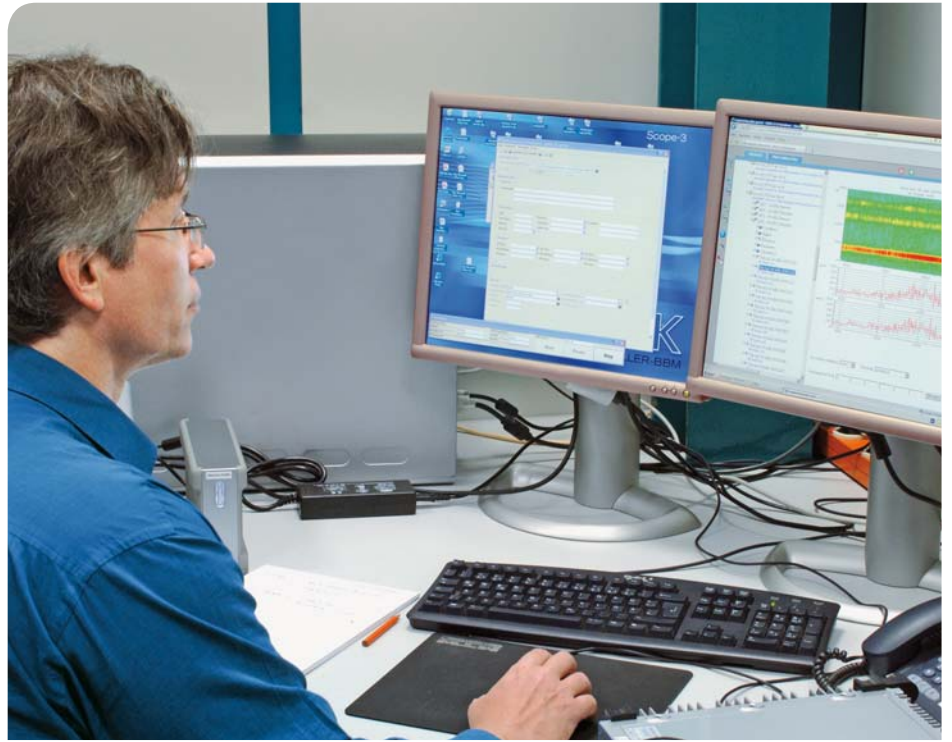

Dynamic Data System: Analysing station.



Turbine vane with hot film array for boundary layer investigations.

Make your business fly!



MTU Aero Engines AG
Dachauer Straße 665
80995 Munich • Germany
Tel. +49 89 1489-0
Fax +49 89 1489-5500
E-mail karin.wolf@mtu.de
www.mtu-aero-solutions.com